

SPECIFICATIONS:

Voltage Rating: 125V AC/DC
 Current Rating: 1A
 Withstand voltage: 500V AC
 Operating Temperature: -25°C~+85°C
 Insulation Resistance: 100MΩ min.
 Contact Resistance: 30mΩ max.

MATERIAL:

Terminal: Phosphor Bronze
 Housing: LCP, UL94V-0
 Fitting Nail: Brass, Tin Plated

PIN	DIM A	DIM B	DIM C
2P	1.25	4.25	3.10
3P	2.50	5.50	4.35
4P	3.75	6.75	5.60
5P	5.00	8.00	6.85
6P	6.25	9.25	8.10
7P	7.50	10.50	9.35
8P	8.75	11.75	10.60
9P	10.00	13.00	11.85
10P	11.25	14.25	13.10
11P	12.50	15.50	14.35
12P	13.75	16.75	15.60
13P	15.00	18.00	16.85
14P	16.25	19.25	18.10
15P	17.50	20.50	19.35
16P	18.75	21.75	20.60
17P	20.00	23.00	21.85
18P	21.25	24.25	23.10
19P	22.50	25.50	24.35
20P	23.75	26.75	25.60

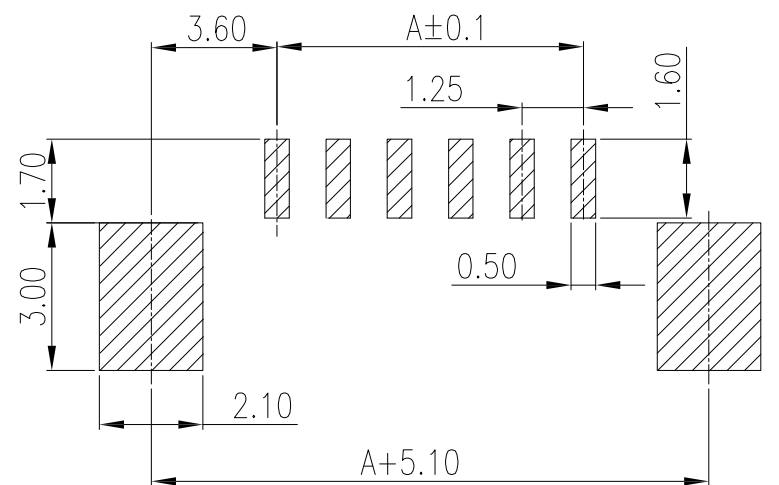
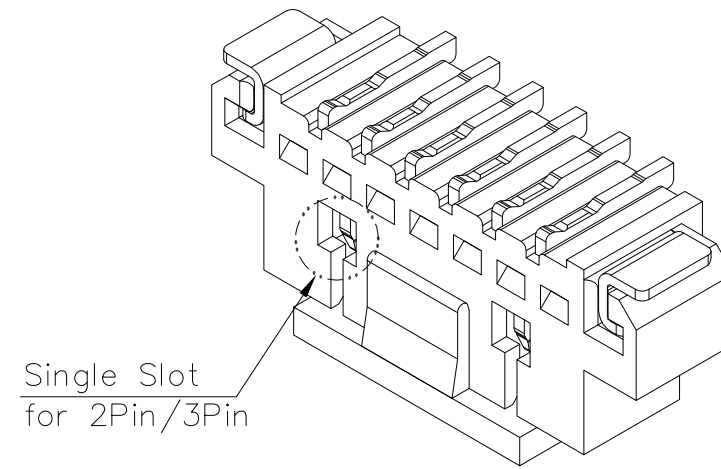

RECOMMENDED PCB LAYOUT

RoHS Compliant

Ordering Information

WE - 4 - XX - PT - LA26-4-369
 1.25Ph Wafer | Solder/PCB 4:SMT VT | 02~20 PIN | Contact Plated PT: Tin | Packing 4: Reel+cap

REV.	REVISION RECORD	DATE	General Tolerance
A	Original	04/15/22	LINEAR 0.0 ±0.25 ANGLE ±3° 0.00 ±0.20
			UNIT: mm
			A4 NAME
			APPROVED KENNY
			DESIGNER GRACE
			DRAWN LANDA



TITLE: 1.25Ph Wafer SMT Vertical 5.3H

DWG.NO: WE4XXPTLA264-369 REV. A

SCALE 1 : 1 SHEET 1 OF 1